

# QUAD OUTPUT PANEL MOUNT SOLID STATE SYNCHRO SIGNAL CONVERTER (PMSSSSC-4)

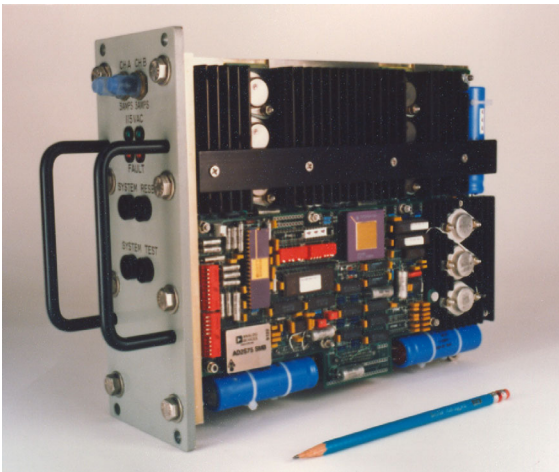

- Performance Superior to Electro-Mechanical SSCs
- Dual Synchro Input / Quad Synchro Output
- Meets Mil-901D Shock
- > 80 khr MTBF (MIL-HDBK-217)
- Virtually Zero Acoustic and Structure-borne Noise
- > 5 VA/channel output
- Easily Drives a Single 15tr4a, Six 15ct6b, or Eight 15ct4c per Channel
- Accuracy Better than 5 arc minutes
- Digital Interface for Synchro-Digital and Digital-Synchro Operation
- Switchboard and Stand-alone Applications

The ASC Panel Mount Solid State Synchro Signal Converter is the superior alternative to electromechanical synchro signal converters. The ASC PMSSSSC-4 replaces ALL dual-input, quad-output EM SSCs, and adds features not available with any EM SSC: sum and difference of angles, switch-selectable speed conversion, digital I/O, remote fault reporting, absence of acoustic and structure-borne noise and vibration, solid-state reliability, improved logistics, and reduced lifecycle costs.

The PMSSSSC-4 accepts 1X/36X inputs (60 or 400 Hz) and outputs TWO PAIRS of 1X/36X outputs (60 or 400 Hz). Each synchro output can supply more than 5 VA, enough to easily drive a single 15tr4a torque receiver or as many as six 15ct6b or eight 15ct4c control transformers.

The ASC PMSSSSC-4 is also exceptionally rugged. Its synchro output amplifiers utilize the latest high-voltage power hybrid operational amplifier technology. The PMSSSSC-4 is fully protected against all output fault, input and output voltage transient, and over-temperature conditions.

Like the 50 VA dual output PMSSSSC, the PMSSSSC-4 is virtually silent at better than 30 dB below MIL-STD-740-1 (A3) for airborne noise, better than 20 dB below MIL-STD-740-2 for structure-borne noise, both measured under worst-case conditions of load and frequency of operation; in usual operation Panel Mount Solid State Synchro Signal Converter airborne and structure-borne noise performance approach the residual levels of the finest instrumentation.

An optional RFI/EMI shielded enclosure is available for stand-alone applications.

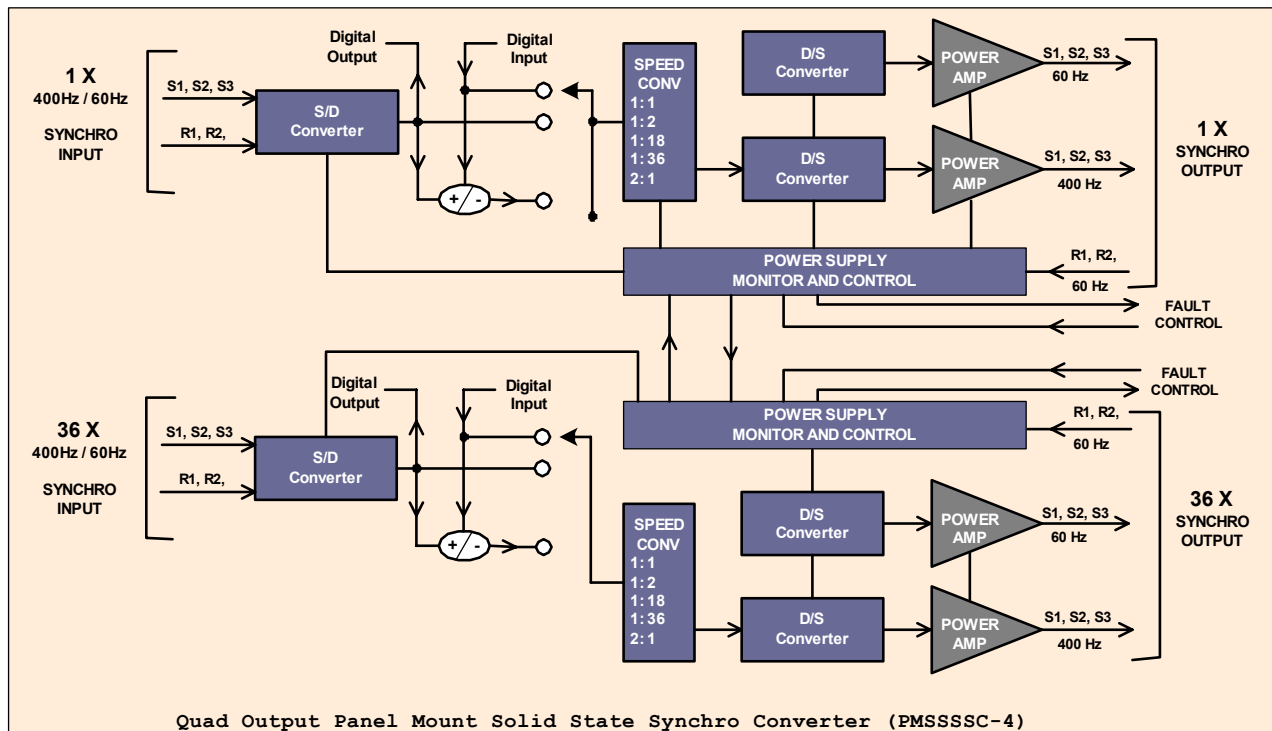

<b><u>SPECIFICATIONS:</u></b>	Quad Output Panel Mount Solid State Synchro Signal Converter
<b>CONFIGURATION:</b>	Dual channel, separate synchro inputs for each channel. Each channel has a pair of synchro outputs, one of which is operated off the power supply of its opposite channel. Each channel has separate digital I/O, control and monitor circuitry, and speed/angle conversion.
<b>SYNCHRO INPUTS (EACH CHANNEL):</b>	55–20 kHz 11.8–90 V synchro, >100 k $\Omega$ input impedance, transformer isolated. Max 70 RPS (4200 RPM) at 400 Hz.
<b>SYNCHRO OUTPUTS (EACH CHANNEL):</b>	2 X 60/400 Hz 90 V synchro (independent of input). > 5 VA. Active (TR) or passive (CTR) loads. < 20 $\Omega$ output impedance. Fully-protected against all output faults.
<b>POWER:</b>	Each channel is reference-powered from its own synchro output reference. Loss of reference will also cancel the corresponding output in the opposite channel.
<b>DIGITAL I/O:</b>	RS-422 (balanced differential) 16-bit serial digital synchro inputs & digital synchro outputs. I/O data rates up to 5 Mbits/sec.
<b>SSC ACCURACY:</b>	< 5 arc minutes (1 :1, 5 VA output).
<b>SYNCHRO/DIGITAL ACCURACY:</b>	< 3 arc minutes.
<b>SPEED/ANGLE CONVERSIONS:</b>	1:1, 1:2, 1:18, 1:32, 1:36, 2:1 switch selected. Sum of angles, difference of angles using digital I/O between channels.
<b>ENVIRONMENTAL:</b>	-25 to +65 ° C ambient operating. 95% Relative Humidity at 0 – 50 ° C. Meets Mil-S-901 D shock. Meets Mil-STD-167 -1 Type 1 vibration.
<b>RELIABILITY:</b>	> 80 khr MTBF @ 65 ° C ambient (MIL-HDBK-217). < 0.5 hr MTTR. NO adjustment, scheduled or preventative maintenance required.
<b>PROTECTION:</b>	Full Safe-Operating-Area & over temperature protected. PMSSSSC can not be damaged by any output load condition. Load/PMSSSSC fault-detection, shutdown and reporting for each channel. Synchro inputs and outputs are transient/lightning strike protected.
<b>FAULT REPORTING:</b>	Relay contact closure and RS-422 for each channel.
<b>OTHER FEATURES:</b>	Full loopback Built-in-Test (operator/remote initiated and reporting). Remote reset/shutdown/synchro output disable (RS-422). Full MIL CLASS B (883B) construction.
<b>WEIGHT:</b>	25 lbs.
<b>MOUNTING:</b>	Standard Navy switchboard mounting. Optional RFI/EMI shielded and unshielded enclosures are available from ASC for stand-alone applications.
<b>SPECIAL APPLICATIONS:</b>	Alternative speed/angle conversions, synchro/resolver levels or frequencies and digital interfaces are available.

ADVANCED SYSTEMS CONCEPTS Inc.  
 225 Lincoln Hwy  
 Fairless Hills, PA 19030 USA  
 Tel: 800-775-0544 / 267-580-0292  
 Fax: 267-580-029

For more information, please contact  
[inquiry@advanced-systems-concepts.com](mailto:inquiry@advanced-systems-concepts.com)  
 or  
[zayzit@advanced-systems-concepts.com](mailto:zayzit@advanced-systems-concepts.com)