

# SYNCHRO/DIGITAL & DIGITAL/SYNCHRO CONVERSION FOR THE IBM PC

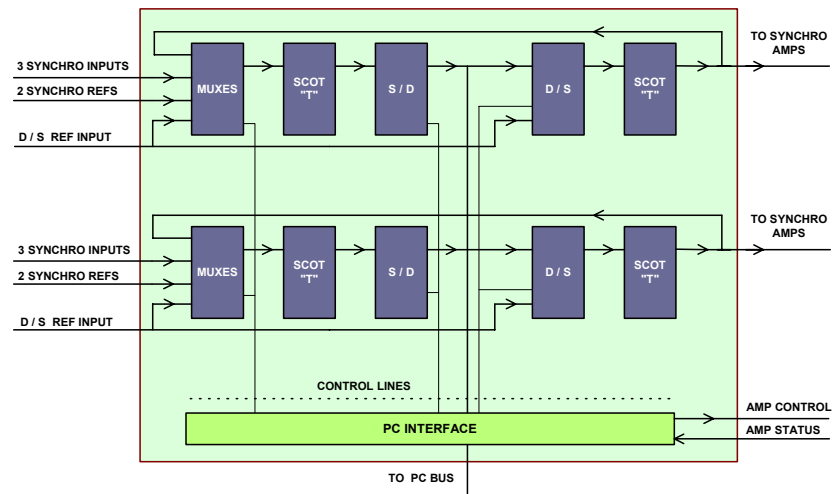
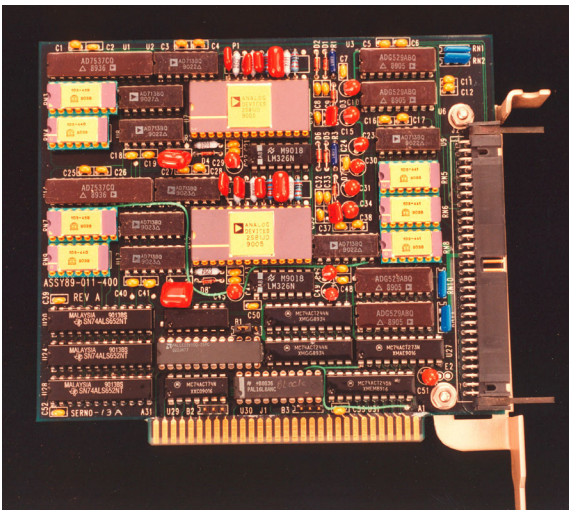

The ASC SDDS-2-12 is a dual-channel synchro-to-digital and digital-to-synchro converter subsystem for the IBM PC XT/AT and compatibles. The card contains two independent S/D converters, each with its own 4-way mux and two independent D/S converters, all under CPU-control. Specific features of this configuration are combined fine/coarse (36X /1X or 32X /1X) I/O capabilities, and the ability to perform self-contained (loop-back) built-in-test. Furthermore, by virtue of its input muxes, a single SDDS-2-12 can serve to monitor as many as 6 synchro inputs.

The SDDS-2-12 uses precision solid-state Scot Ts for internal synchro-resolver and resolver-synchro conversion. All synchro levels are nominal 2 Vrms leg-leg for 2.6 Vrms reference level. Resolution is 12-bits for all converters. Accuracy of D/S conversion is better than 8 arc minutes; accuracy of S/D conversion is typically better than 15 arc minutes, 30 arc minutes guaranteed; both numbers apply over the  $-0^{\circ}$  to  $+70^{\circ}$  C temperature range (consult the factory for higher-accuracy or extended temperature range versions).

In most applications the SDDS-2-12 synchro outputs will be amplified to 90 V, 26 V or 11.8 V leg-leg levels, depending on application; the SDDS-2-12 provides external synchro power amplifier monitoring and control for each channel. Companion dual channel synchro power amps (such as the SPA-9050 75 VA/90 W reference-powered 90 V synchro power amplifier) are available from ASC.

S/D converters are normally factory-configured for 60 or 400 Hz operation, according to customer requirements, as well as customer-required maximum tracking rates up to 130 RPS. Velocity outputs may be brought out to 60pin I/O connector. In addition, an interrupt on major carry is available and may be jumper-configured to IRQ3 or IRQ5. D/S converters require no configuration and can be operated with reference frequencies as high as 100 kHz. Maximum D/S angle rates will be limited only by the associated IBM PC and/or its I/O bus rates.

The SDDS-2-12 incorporates its own on-card  $\pm 12$  V tracking regulators for each channel for improved analog performance and immunity from PC-supply noise and load variations. The card requires  $\pm 15$  V supplies at 0.25 A, supplied through its 60 pin I/O connector.

The SDDS-2-12 is exceptionally compact for its capabilities, occupying less than 1/2 the normal IBM PC card length, making it suitable for use in tight space-restricted applications. The high density is made possible by an 8-layer printed circuit board design. The SDDS-2-12 is designed and constructed for reliable operation in rugged shipborne environments, and is normally supplied conformally coated to MIL-I-46058 type PUR. A version without conformal coating, the SDDS-2-12-NC, is available for operation in less hostile environments.

A demonstration/test diskette containing programming examples is included along with the comprehensive technical manual.

**DESCRIPTION:**

Dual channel Synchro-to-digital and Digital-to-synchro converter card for the IBM PC and compatibles. The dual channel configuration is particularly suited for fine/coarse (1X /36X) applications. The SDDS-2-12 is designed for control/monitoring of associated synchro power amplifiers such as the ASC SPA-9050 dual 75 VA /90 W synchro power amp.

**SPECIFICATIONS:**

|  |  |
|--|--|
| <b>SYNCHRO INPUTS:</b>                   | <p>3 software-selectable synchro and reference inputs for each S/D converter channel;<br/>         1 loop-back from the channel's D/S converter output.<br/>         All synchro inputs are 2 Vrms L- L nominal 400/60 Hz. Input impedance is 500 kΩ.<br/>         All reference inputs are 2.6 Vrms nominal (115V Ref Hi and Ref Lo each applied through external 56.2 kΩ resistors).<br/>         Resolution is 12 bits.</p> |
| <b>SYNCHRO OUTPUTS:</b>                  | <p>2 X 2 Vrms L- L ±1% at nominal reference levels.<br/>         Reference inputs are 2.6 Vrms nominal (115V Ref Hi and Ref Lo each applied through external 56.2 kΩ resistors).<br/>         Resolution is 12 bits.</p>   |
| <b>ACCURACY:</b>                         | <p>SID - 15 arc minutes typical,<br/>         30 arc minutes guaranteed.<br/>         D/S - 8 arc minutes guaranteed.</p>  |
| <b>SYNCHRO POWER AMPLIFIER CONTROLS:</b> | <p>2 X enable (TTL - level).<br/>         2 X 3 BITS SPARE (TTL - level).<br/>         Drive is 2 standard TTL loads.</p>  |
| <b>SPA MONITORING:</b>                   | <p>2 X PS fault (TTL - level)<br/>         2 X SOA protect (TTL - level)<br/>         2 X Thermal overload (TTL - level)</p>   |
| <b>MAX S/D TRACKING RATE:</b>            | <p>130 revolutions per second, or 1/4 of reference frequency, whichever is less. Velocity outputs are available on input/output connector.</p>   |
| <b>MAX D/S ANGLE RATE:</b>               | <p>Limited only by IBM PC and/or I/O bus rates.</p>  |
| <b>BUILT-IN-TEST:</b>                    | <p>Each D/S converter may be looped-back to its associated S/D converter for full on-board end-to-end test under software control. In this case, the S/D converter takes as its reference the D/S converter reference. The on-board loop-back test may also be supplemented by off-board loop-back test such as from associated synchro power amplifiers like the SPA-9050 synchro power amp.</p>                              |
| <b>PC-INTERFACE:</b>                     | <p>Standard IBM PC 8-bit or 16-bit bus slot. Base address is jumper-configurable to allow up to four SDDS-2-12 cards to be used per IBM PC. One or both S/D channels may be configured for interrupt on major carry and board may be jumper-configured for IRQ3 or IRQ5.</p>   |
| <b>I/O INTERFACE:</b>                    | <p>60-pin connector with latching ejectors. Mating connector is AMP 1-102387-1 or equivalent.</p>  |
| <b>DIMENSIONS:</b>                       | <p>Approximately 4.8" high X 5-1/2" long.</p>  |
| <b>POWER REQUIREMENTS:</b>               | <p>+ 5 V @ 0.5 A<br/>         ± 15 V @ 0.25 A</p>  |
| <b>ENVIRONMENTAL:</b>                    | <p>Operating: 0° C to + 70° C<br/>         Storage: -45° C to + 125° C</p>   |

ADVANCED SYSTEMS CONCEPTS Inc.  
 225 Lincoln Hwy  
 Fairless Hills, PA 19030 USA  
 Tel: 800-775-0544 / 267-580-0292  
 Fax: 267-580-029

For more information, please contact  
[inquiry@advanced-systems-concepts.com](mailto:inquiry@advanced-systems-concepts.com)  
 or  
[zayzit@advanced-systems-concepts.com](mailto:zayzit@advanced-systems-concepts.com)